



Natoli's
Definitive Guide to
**MULTI-TIP
TOOLING**

Which is the **BEST**
Tool for You?

We Set the Standard That Others Follow

For over 40 years, **Natoli Engineering Company**, has been at the vanguard of tablet compression tooling design and manufacturing. The groundbreaking introduction of our family of multi-tip punches more than three decades ago was influential in altering the course and process of tablet manufacturing. Our custom engineered tooling is reputed as the industry gold standard, prompting many imitators but no true competitors.

At **Natoli Engineering Company**, we custom engineer and craft a wide range of precision multi-tip punches in various configurations to our customers' exact specifications. These include all types of tablet compression tooling: standard and micro-tab, solid and assembly-style punches for round, shaped and custom designed tablets.

Our multi-tip tooling meets or exceeds today's increasing demands for maximizing tablet production.

Switching to multi-tip tooling may be intimidating for some companies, but our expert team is always available and eager to help you with valuable one-on-one coaching and training, insightful advice and time-saving recommendations.

We can also support your team in creating custom SOPs to help walk you through critical procedures step by step.

Customer satisfaction is the most important part of our business. We are dedicated to your success and ensuring you reach your goals. Together, anything is possible.

*"We are dedicated to innovative design,
quality manufacturing, quick turnaround,
unmatched customer service and
ensuring our customers' success."*

Dale Natoli - President

How Many Tips?

Multiple Designs – Multiple Benefits

- Significantly increase tablet production
- Fewer presses, reduce press run time with higher production levels
- Dramatically cut operating costs and increase efficiency
- Requires less storage space for tooling

The chart on facing page indicates the maximum number of tips that can fit on the most common “B” and “D” tooling for standard assembled and solid type, multi-tip punches. Special multi-tip designs for other sizes and other tool types are also available.

Recommended to utilize taper in die bores to reduce compression force, and even more so, reduce ejection forces.



Performance and production level depends on: tooling type, size and shape of tablet, performance of powder, tablet configuration, compression force, condition and speed of turret, and operator experience.

Maximum Number of Tips Per Tool

Die Size		Solid Punch Tips				Assembled Tips			
Inches	mm	"B" Punch	"B" Punch with Dust Cup	"D" Punch	"D" Punch with Dust Cup	"B" Punch	"B" Punch with Dust Cup	"D" Punch	"D" Punch with Dust Cup
0.0394	1.00	†	†	†	†	37*	37*	65*	65*
0.0591	1.50	†	†	†	†	29*	23*	43*	43*
0.0787	2.00	†	†	†	†	19	19	35*	35*
0.0984	2.50	†	†	†	†	9	9	19	19
0.1181	3.00	†	†	†	†	9	9	20	20
0.1378	3.50	†	†	†	†	7	7	14	14
0.1575	4.00	†	†	†	†	7	7	14	14
0.1772	4.50	†	†	†	†	4	4	8	8
0.1969	5.00	5	5	6	6	4	4	8**	8**
0.2165	5.50	4	4	6	6	3	3	7	7
0.2362	6.00	4	4	6	6	4	3	5**	5**
0.2559	6.50	4	4	6	6	3	3	5	5
0.2756	7.00	3	3	5	5	2	2	5	5
0.2953	7.50	2	2	4	4	1	1	4	4
0.3150	8.00	2	2	4	4	1	1	3	3
0.3346	8.50	2	2	3	3	1	1	3	3
0.3543	9.00	1	1	3	3	1	1	3	3
0.3740	9.50	1	1	3	3	1	1	2	2
0.3937	10.00	1	1	3	3	1	1	2	2
0.4134	10.50	1	1	3	3	1	1	1	1
0.4331	11.00	1	1	2	2	1	1	1	1

†Tips 4.50mm and smaller are not recommended for solid punch designs. Small tips are easily distorted and damaged, but can be individually replaced on assembled style tooling.

*Maximum number of tips possible. However, the maximum number of tips may not be recommended to achieve optimal press operation.

**Maximum number of tips using standard tool/tip configurations. More tips may be possible using special tool/tip configurations, however this will increase cost and lead time.

Dependant on: powder flow, feeder configuration, required compression and ejection force.

Maximizing the number of tips is not necessarily the best practice.

Assembly vs. Solid Multi-Tip Punches

Which Punch is Right for You?

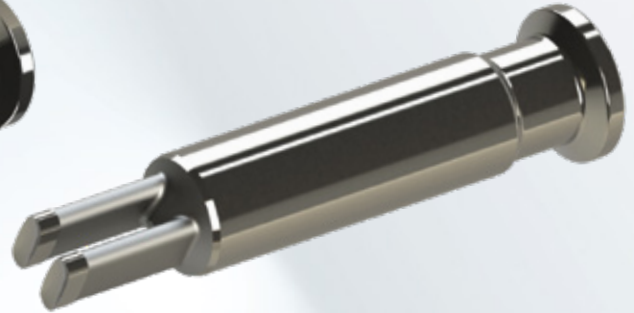
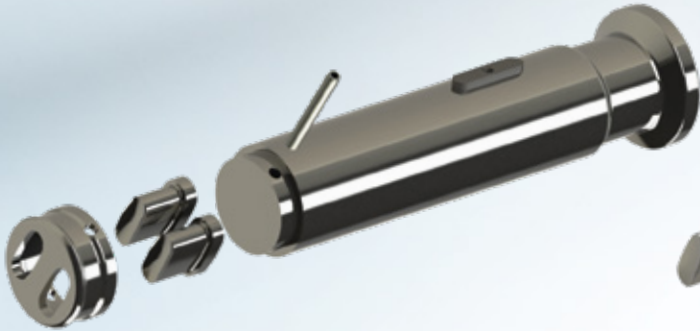

Assembly Multi-Tip

Our assembly-style, multi-tip punches consist of a punch body, cap and individual tips.

Special Features

- Tips may be replaced individually saving costs
- Material of tip and punch body may be optimized according to granulation and compression characteristics

Solid Multi-Tip

As the name implies, our solid punches are crafted from one single piece of high-quality steel, designed to reduce cleaning time and maintenance.

Special Features

- No assembly or disassembly
- Simplifies cleaning
- Reduces contamination risk
- May allow for more and larger tips

Micro-Tab Punches

Small but Mighty

Micro-tab tooling utilizes a unique configuration. Shortening the upper and lower punch tips **increases the mechanical strength to withstand compression forces**, while reducing the possibility of distortion or breakage. Micro-tab tooling should be considered for all tablets 5mm in diameter and under. Exclusively used for assembly-style punches and available for both round or shaped tablets.

Upper Micro-Tab Punches



For Use
with
Standard
Die

For Use
with
Under-Cut
Die

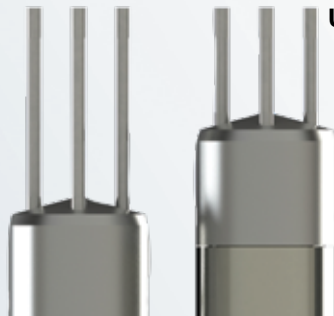

Lower Micro-Tab Punches

Under-Cut Dies

Increase Strength

Decrease Distortion

Small diameter punch tips have a propensity to distort and break due to compression loads and rotational force of the turret. Our unique under-cut die solves this problem. The lower punch barrel is partially inserted inside the under-cut die, accommodating shortened punch tips. This increases the tips' strength and durability, resulting in the manufacturing of more consistent tablet specifications. The use of under-cut dies requires the use of shallow fill cams and effective lower punch retainers/brakes or filler plates.

Standard Die



Under-Cut Die

Rotating Punch Heads

Reduce Stress on Tips

Rotating punch heads are engineered as a two-part configuration to significantly extend the life of your multi-tip tooling. This critical design allows the punch head to rotate independently of the punch body, allowing for evenly distributed head wear and reduced gouging, and is the preferred option for small and micro-tab tooling.

The rotating punch head option eliminates torque and greatly reduces friction subjected to the punch tips by eliminating the punch's inclination to rotate throughout the compression cycle.

Various levels of stress
von Mises (psi)

Without
rotating head

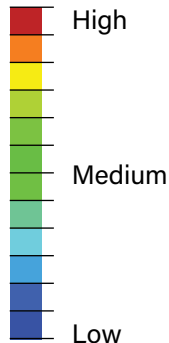

With
rotating head

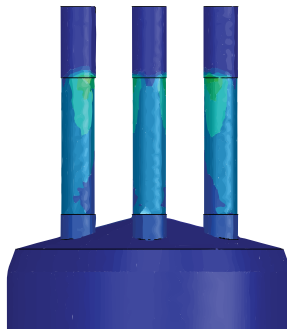

Due to lower punch tip alignment requirements, punches with rotating heads can be more challenging to install

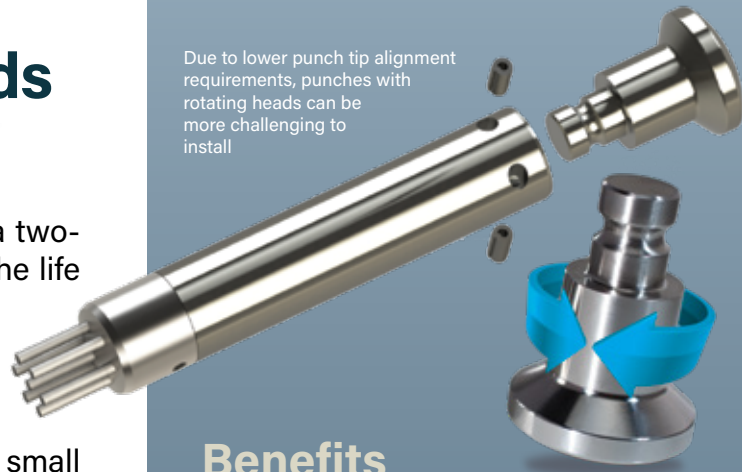

Benefits

Not only a money saver but a problem solver, offering a variety of key benefits to the production operation:

- Reduces possibility of lower punch tip bending, distortion, and breakage
- Back-angle wear is drastically reduced, resulting in less head wear and overall longer punch service life
- Allows for easy replacement of the head, resulting in significant revenue savings
- May allow for increased tablet press operating speed

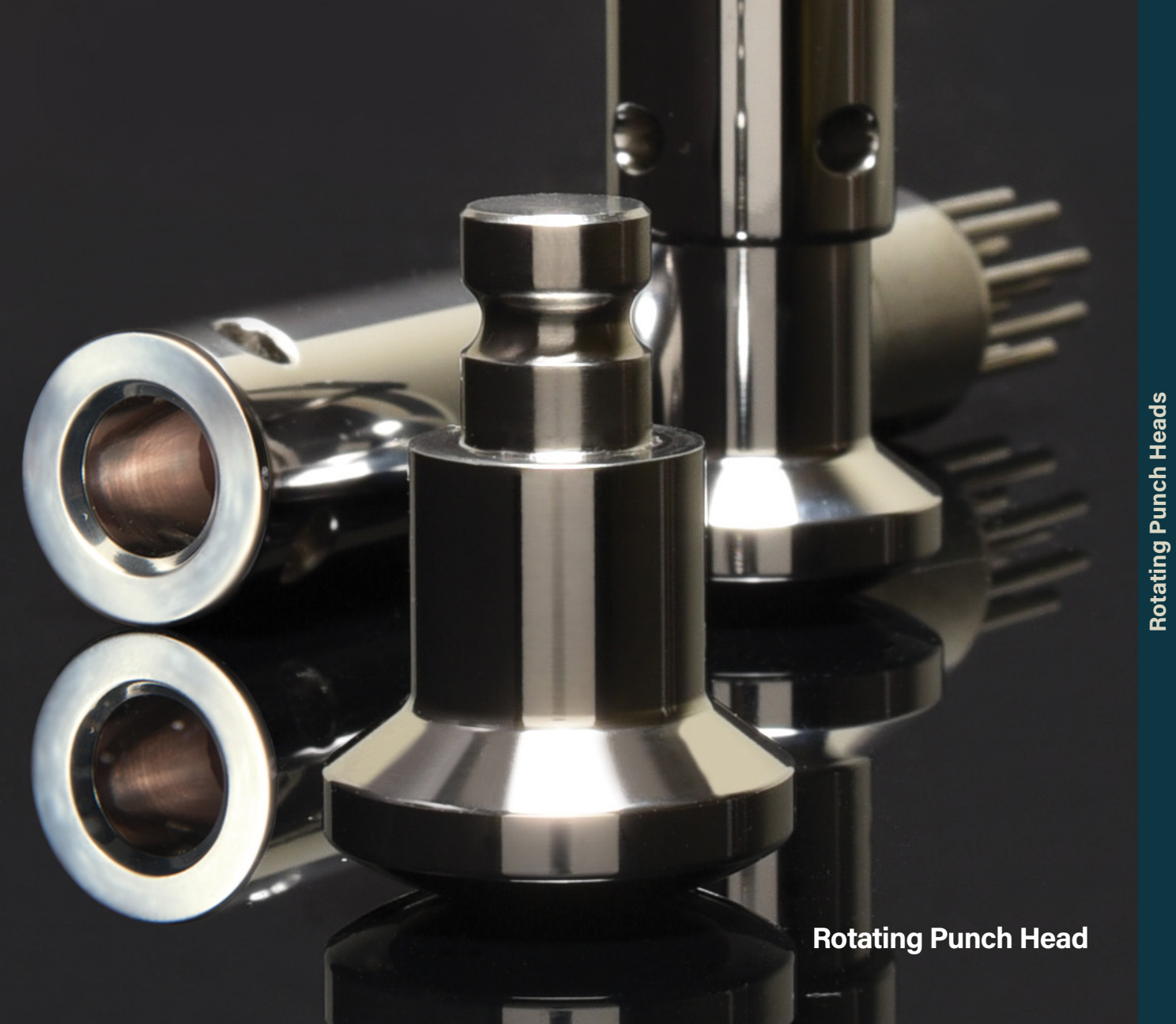

Rotating Punch Head

*"We are not believers in the
if it isn't broke, don't fix it, mindset.
Innovation is the key to success
and progress."*



**Vented Caps
for Easier Cleaning**

NEW INNOVATION!

Vented Cap Design for Assembled Multi-Tip

Easy Maintenance — Quick Cleanup

Always imagining new designs and ways to make our customers' lives easier while saving time and revenue, therefore, we developed our unique vented multi-tip cap.

Now maintaining and cleaning your multi-tip punch has never been simpler or quicker: clean, rinse and dry without the need for disassembly.

Our vented caps have 3-4 slots machined into the sides so cleaning solutions can easily flush through and drain.

Compressed air can then be directed into the vent slots to ensure complete drying.



Multi-Bore Die Segments

**Quality + Precision =
Increased Productivity & Cost Savings**

Our multi-bore die segments afford the flexibility to increase the number of stations per press and increase production by compressing more tablets per revolution.

Die segments replace conventional die tables, dies and die locks, for specifically manufactured presses.

When multi-tip punches are combined with multi-bore die segments, tablet production is dramatically increased.

Also available in tungsten carbide liner for better wear and longevity. High-tech ceramic line of die segments coming soon.

**Multi-Bore
Die Segment**



Multi-Tip Reject Verification Tool

Sometimes Being Rejected is a Good Thing...and a Cost Saver

Is your tablet press reject system calibrated and ready to handle multi-tip tooling? If not, you could be losing productivity and revenue. There is a simple way to test your reject system yourself without hiring an expensive outside service.

Benefits

- Easy to set up and test your rejection system
- Verify the reject system within minutes
- Fix the problem — crank up production — save money



Utilizing our specially designed Multi-tip Reject Verification Tool makes it easy to validate the tablet reject system. Our “reject” upper punch is intentionally engineered to be shorter, or longer, than the other punches in the set to simulate under- and overweight tablets. These out-of-specification tablets should trigger the press reject system and divert them to the reject chute. The rejected tablets are easily identified by the X or RT mark made by the specially designed “reject” tool.

Natoli Steel

Proper Steel Selection is Critical

Steel selection is critical to tablet production consistency and success. Using the “hardest” steel is not always the best choice, because hardness doesn’t always equate to the highest tensile strength, which may be required when utilizing multi-tip tooling.

Maintaining the industry’s largest inventory of tool steel ensures we have the highest grade punch and die material on hand to meet your exact requirements. Never wait for steel.

All Natoli steel is quality tested for composition and purity, and then measured against the strictest standards – making our tablet compression tooling the best in the industry.

Adhering to the strictest industry guidelines, we ensure our steel quality is not compromised by using the test procedures established by the American Society of Testing and Materials.

Natoli Steel

Natoli inventories a one-year supply of 16 common grades of tool steel at our on-site facility:

- Standard Grade: S-7, S-1, 3Ni
- Premium Grade: D-2, DC-53, A-2, M-2, K-340, D-3
- Premium Grade Corrosion Resistant / High Chrome: 440C, M-340
- Premium Grade Specialty: PM-3V, PM-9V, PM-10V, PM-15V, PM-M4

Our steel quality control procedures are designed to provide maximum tooling life and are regarded as the best in the industry.

"You can rely on our high-quality materials, expert advice and service to meet your challenges."

Natoli Steel Quality Specification Chart

Steel Type	Steel Grade	Tooling Type		Hardness Rockwell C	Benefits			
		Punch	Die		Wear Resistant	Improved Toughness	Corrosion Resistant	Comprehensive Strength
S-7	Standard	•	—	56 - 58	—	•	—	•
S-1	Standard	•	—	56 - 58	—	•	—	•
3Ni	Standard	•	—	53 - 55	—	•	—	•
D-2	Premium	•	—	58 - 60	•	•	•	—
DC-53	Premium	•	—	59 - 61	•	•	•	•
A-2	Premium	•	•	58 - 60	—	•	—	—
M-2	Premium	•	•	58 - 60	—	•	—	—
K-340	Premium	•	—	58 - 60	•	•	—	•
D-3	Premium	—	•	59 - 61	•	•	—	•
440C	Premium	•	•	54 - 56	—	—	•	—
M-340	Premium	•	•	56 - 58	•	—	•	—
PM-3V	Specialty	•	—	56 - 58	•	•	—	•
PM-9V	Specialty	•	•	53 - 55	•	•	—	—
PM-10V	Specialty	•	•	58 - 60	•	•	—	—
PM-15V	Specialty	—	•	59 - 61	•	•	—	—
PM-M4	Specialty	•	—	58 - 60	•	•	—	—

The ASTM E45 International Steel Testing Procedure is the test method used to determine the quality and cleanliness of tool steel.



NATOLI

NATOLI

Steel Coatings

Quality Solutions for Tableting Complications

Many common tableting issues, such as sticking and picking, may be reduced by applying a specialized coating to your tooling. Our numerous coatings are designed to provide practical options based on the tablet formulation being compressed and to improve the quality and efficiency of your tableting operation.

Natoli has a specific coating solution to meet your every need. Whether you require enhanced product release or improved wear resistance, one of our coating options is sure to meet your requirements. For example, a chrome or chrome nitride coating will reduce the propensity for powders to adhere to the punch face. We also offer a proprietary coating, **Natoli Ultracoat**, which is superior to electro-process chrome and improves punch wear resistance, tool life and lubricity, which reduces sticking.

Although specialized coatings for multi-tip tooling are generally reserved for problematic formulations, we do not recommend that you rely solely on coatings to compress a specific product. We typically recommend solving these compression problems by using a specific steel that possesses the same or better properties.

We are happy to discuss your exact needs and the challenges you are facing that may require a specialized coating or tool steel.

Frequently Asked Questions

1

Q. How long has Natoli been manufacturing multi-tip punches?

A. More than three decades.

2

Q. Are all of Natoli's punches custom made?

A. Yes. All tools are made to the customer's exact specifications.

3

Q. What is the smallest tip size available?

A. 1.0mm for round, assembly-type micro-tab tooling. 4mm for round, solid-type multi-tip tooling. Smaller sizes may be available per special request. Shaped tooling needs to be assessed.

4

Q. How many tips can be on a single punch?

A. Number of tips depends on tablet size, tablet shape, tool size, multi-tip punch configuration, and powder flow characteristics.

5

Q. What is the lead time in receiving a multi-tip punch order once it has been placed?

A. Obviously, there are many variables to consider: number of tips, plain vs. embossed, coatings, number of punches and dies. That said, Natoli has earned the reputation for turning multi-tip punch orders around faster than anyone in the industry.

6

Q. Can multi-tip tooling be repaired and refurbished?

A. Yes, in most cases. A detailed inspection and assessment is performed and then it is determined if the tooling can be repaired or if certain components need to be replaced. Damaged tips on solid punches generally require replacement of the entire punch.

7

Q. How do I clean multi-tip punches?

A. Our recommendation is to use the **Natoli Ultrasonic Cleaning System** with the proper cleaning solution and PH balance to eliminate potential discoloration. Immediate and thorough drying is essential. Vented caps are slotted to allow cleaning solutions to pass through and ensure complete dry time.

8

Q. How do I polish multi-tip punches?

A. Automated polishing may be performed, but this may not restore the critical punch edge. Punches can also be polished using polishing paste with fine brushes for more controlled and detailed results. Buffing methods are preferred, but it is mandatory that your tooling technicians be trained by a Natoli specialist.

9

Q. What is the maximum force that can be applied to multi-tip tooling?

A. The mathematical equation, in theory, is the force for a single tip multiplied by number of tips and adjusted based on a Factor of Safety to account for the fatigue life of the tooling.

10

Q. Do I set up multi-tip tooling differently than a shaped punch in a tablet press?

A. No. Both styles of punches are set in the same exact fashion. However, It is recommended that you utilize a **Natoli Press Set-Up Toolbox** outfitted with custom tools made specifically for your brand press. Using the correct tools will reduce set-up time and eliminate damage to presses and tooling.

11

Q. What if my turret is worn?

A. Use **Natoli's Certified Inspection Kit** to ensure turret is within OEM specifications.

All Natoli products are proudly made in the USA.

Additional Natoli Products & Services

Whether you need training, troubleshooting assistance, or are in need of a specific product or service – we're here to help. Natoli Engineering has the most diligently trained customer service staff in the industry. We can help with tablet compression tooling, tablet presses, compression accessories, laboratory testing, tablet quality issues and more! We offer a variety of products and services worldwide to multiple industries. Our technical service experts are ready to help you manufacture tablets to your exact specifications.

Get started today with the global leader of tablet compression products and services.

- Tooling Design
- Tablet Design
- Tablet Presses & Parts
- Tablet Press Refurbishing
- Compression Accessory Catalog
- Technical Training
- Natoli Scientific
- Natoli Metallurgy



Design Custom Tablets with TabletCAD



Technical and Hands-on Training



Tablet Production Presses

Partner with The Global Leader in Tablet Compression Tooling

- ★ Headquarters
- Distributors
- ▲ Service Center
- Training Center



With more than 60 Natoli sales representatives and distributors worldwide to serve our customers, we can be virtually anywhere at any time to assist you.

Visit natoli.com/about/distributors/ to locate a distributor or sales representative in your area.

We are committed to providing our customers with unsurpassed personalized service and to exceed their expectations with the highest regard for their individual needs – without exception or compromise. For more than 40 years we have dedicated ourselves to earning our customers' loyalty and trust by offering superior products and services backed by our guarantee of satisfaction.

It is our goal to earn your trust and we would like to take this opportunity to understand your business better, the challenges you face and how we can influence positive outcomes to help you reach the level of success you have always imagined.

Call us or visit our website...TODAY!



NATOLI ENGINEERING COMPANY, INC.
636.926.8900 | info@natoli.com | natoli.com

